



# Installation Operating manual

**TESA Electronic and special devices - via Etiopia 7 - 65015  
Montesilvano – PE - ITALY**

Tel. (0039) 085 4175602

[info@tesaitaly.com](mailto:info@tesaitaly.com)

[www.tesaitaly.com](http://www.tesaitaly.com)

<b>contents</b>	<b>Seite</b>
Important remarks	3
Fitting of jacks on the chassis frame	4
Choosing the fitting points	
Vertical length	5
Insertion of lengthening pieces	6
Installation control unit	7
Electrical connection	7
Electrical connection of jacks	8
Initial operation	10
Programming the remote control	12
Control panel	13
Description of buttons	
Control panel	14
Description of LED's	
Detailed description of functions	15
Remote control	17
Signalisation of alarms	17
Special functions	18
Blocking all functions when ignition on	
Special functions	18
Using the system with running motor	
Special functions	18
Auto Power Off	
Signalisation of malfunctions	18/19
Troubleshooting	
Storing the correct levelling	19
Emergency operation	19
warranty	20
Technical data	20

# ! Important remarks

Please read attentively this manual with its detailed information also after the correct. The manufacturer is not responsible for damages and injuries caused by incorrect installation and use of the system.



Use fixing points with sufficient stability. Consider every jack can lift up to 2500 kg. If necessary the fixing points at the chassis must reinforced with adequate parts.



Consider the required space between jack and floor of 35mm at least in vertical position



Do not forget to install the fuse in the +power line and make sure a professional execution of electrical works to guarantee the safety functions



Follow the instructions step by step and complete the chapter "Initial operation" after installing.

## Fitting the jacks on the chassis frame

Please fit the front jacks in converse tipping direction to the rear in order to get the best stability, if possible.

Fit every jack with 4 screws and nuts on the frame like shown in the picture, also in case of using adapters.

### Choosing fitting points

**In difficult conditions the jacks can be welded with adapters.**

**In vertical position of the jacks the space between foot and floor must be 30 mm at least.\***

**Control the required space of the jack. No obstacles in the course!\*\***

\* Delivered length can be extended (see following chapter)

\*\* The travel of the jack can be modified (see chapter adjusting limit switches)

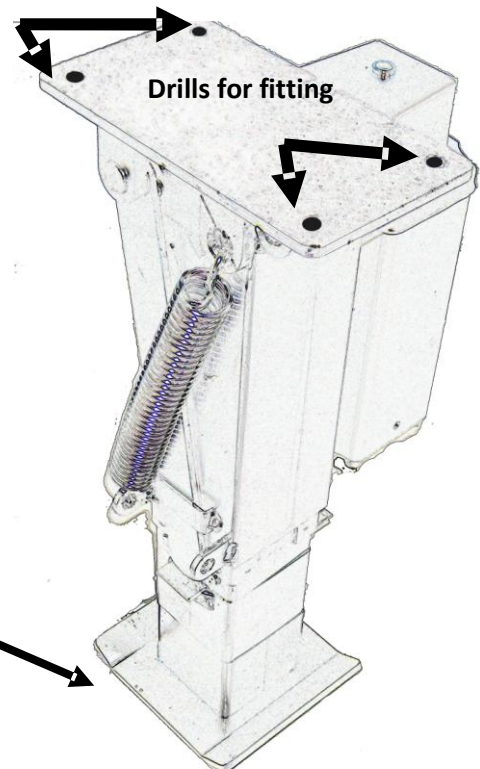
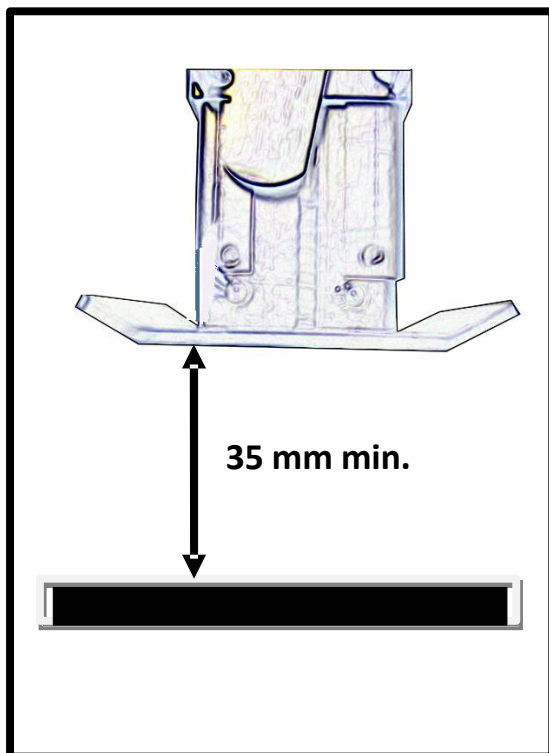

## Vertical length

Make sure there is enough space under the jack at the fitting point.

The jacks are delivered in the manner that measures can be made easy and without groundwork.

If you ignore the minimum space between jack and floor it is possible small asperities can derange the correct course of the jack. Damages on vehicle and jacks are pre-programmed!

For higher frames the jacks can be extended with different pieces in order to reach the correct space. Following lengths are possible:



300 mm

Putting the extensions can obtain the following measures height vertical  
STANDARD 300mm  
With pieces from 320mm to 420mm  
step 10 mm

Standard

# Insertion of lengthening pieces

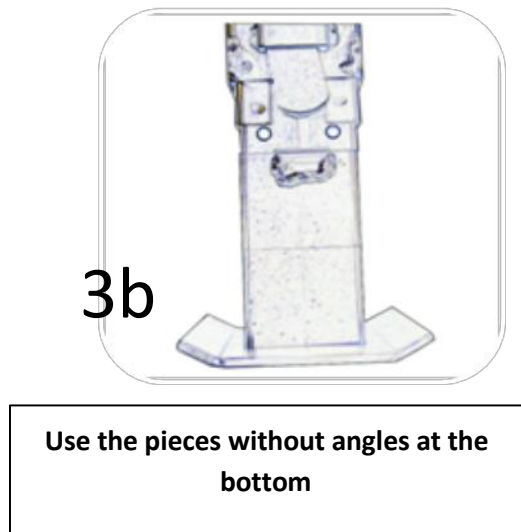
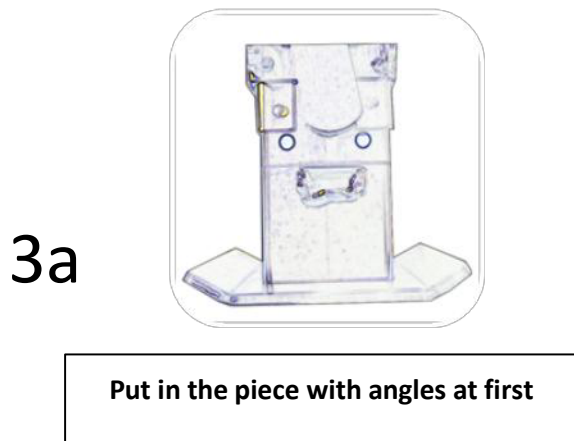
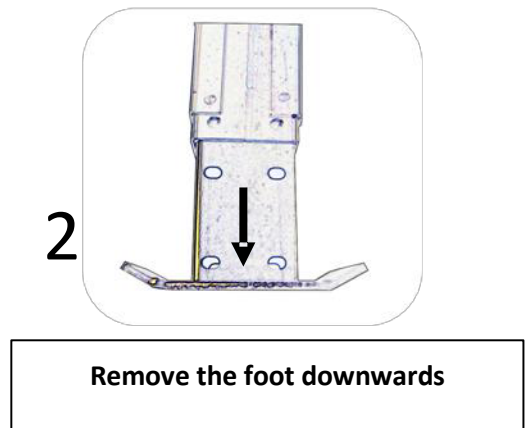
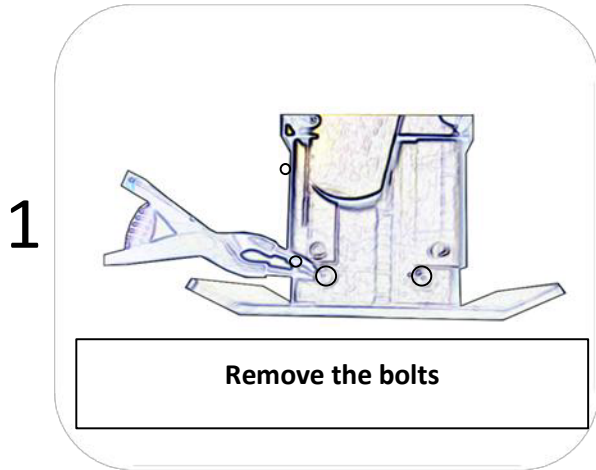

**THE BIGGER ANGLE MUST BE SET ON THE SIDE WITH THE CONTACTS. THE ANGLES MUST BE SET ON THE UPPER SIDE OF THE PIECES!**

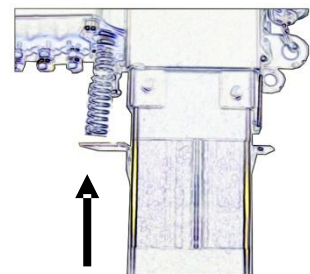

4

**REINSTALL THE BOLTS AND CIRCLIPS.**

## Installation control unit

The control unit is delivered ready pre-wired. Fit the box under the bottom of the vehicle at a center point in the middle.

Following points are important for correct function:

The box with the control unit must be fixed with the bottom up to the vehicle. The bottom of the box and the vehicle must be parallel to each other.

The box must be installed with the arrow showing exactly to the front →

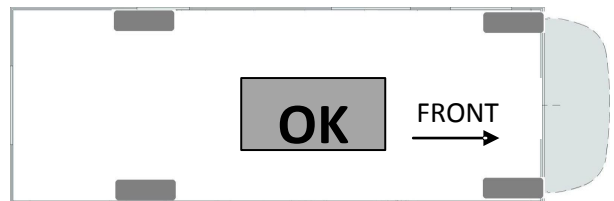
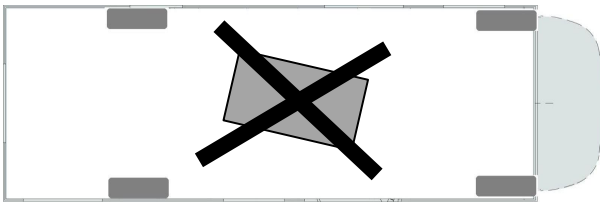

## Electrical connection

The cables on the control unit are numbered. The control unit must be connected with the jacks like shown in the following picture (no. 1 front left, no. 2 front right etc.)

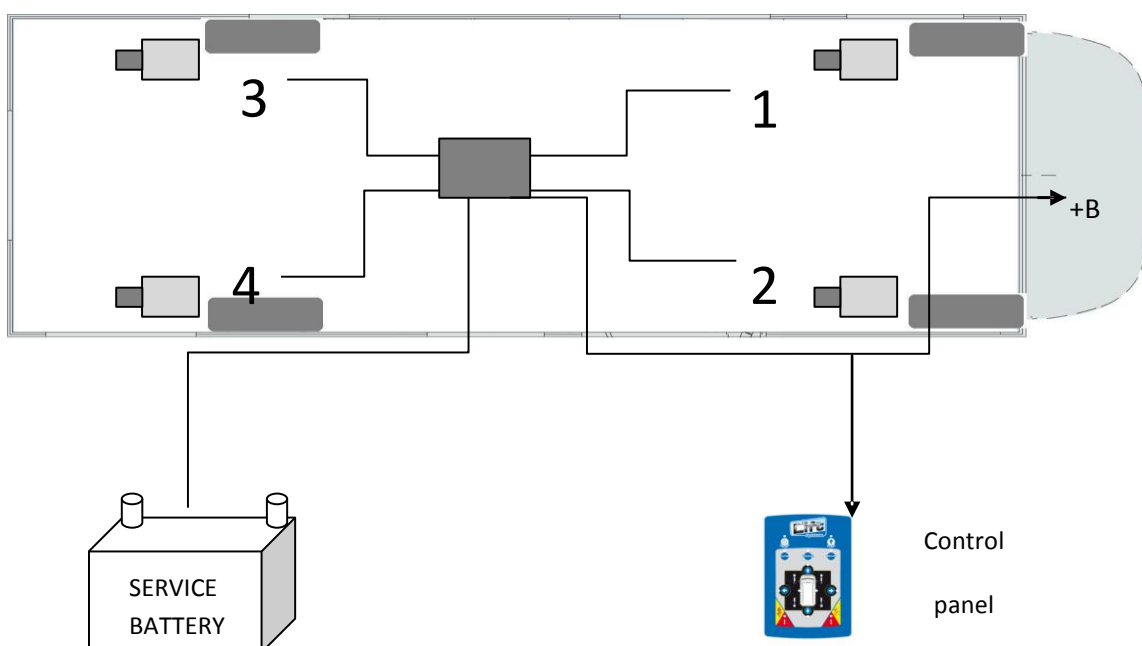

## Electrical connection of jacks

Cable 1 must be connected to jack no. 1. Follow this procedure up to jack no. 4.

Connect the wiring corresponding to the different colours. Pay attention to the optimal pass in order to keep the course of the jack.

Choose the optimal way of fitting corresponding to the tipping direction:

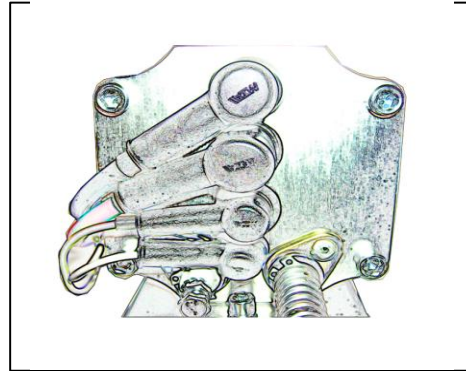
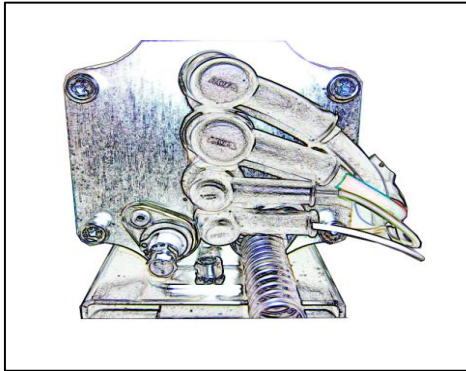

Connect the cables:

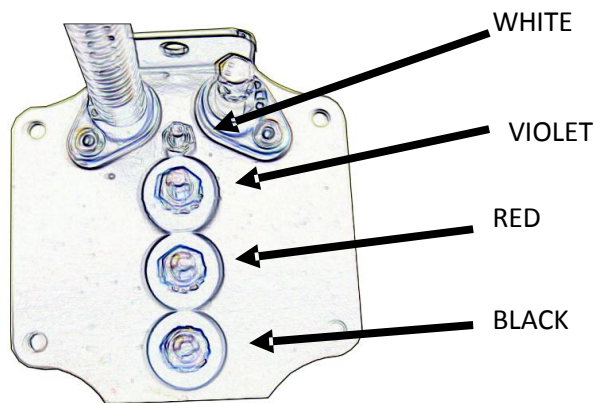

Fix the cables with nuts and spring washers.  
**Attention!** The limit switches must be free from the white cable

### **Important ! only for the violet cable!**

After fitting the violet cable fill the rubber cap with the delivered grease. Not till then fix the rubber cap. This special grease avoids accidental ground with other connections caused by splash water and avoids corrosion caused by de-icing salt. Non-observance will cause function problems of the limit switches in the long run!

Fit the cable at the jack like shown in the pictures.

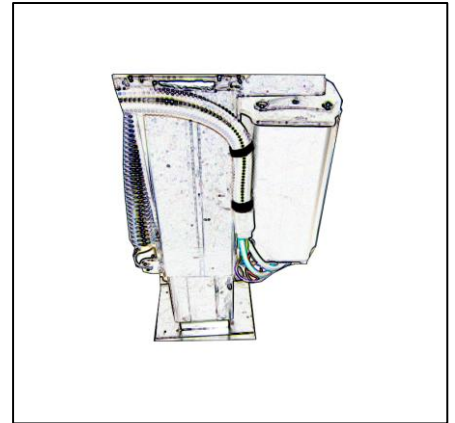
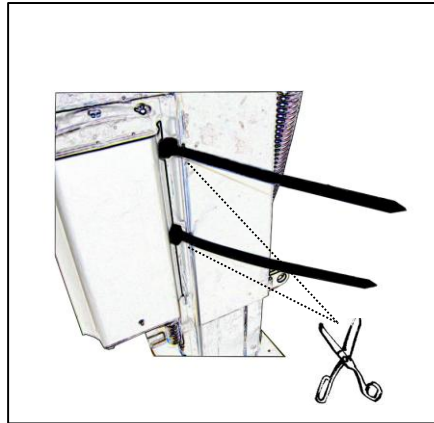

Connect the power line to the battery. RED = + 12Volt BLACK = -12V



**Fit the delivered fuse with box in the RED power cable (+12V) in order to avoid damages on vehicle and jacks**

The control panel can be fitted in the motor home near the door in a position which is reachable from inside and outside. Pay attention for enough space around the panel for special functions with both hands. Connect the network cable on the backside of the panel and the control unit. Das **orangene Kabel (+B)** im Kabelstrang der Bedientafel muss mit +12V über eingeschaltete Zündung verbunden werden.

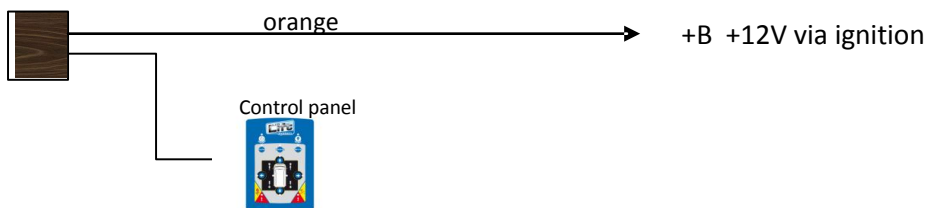

**Later: After passing the wiring and a function test seal the cables tubes with appropriate material to avoid water damages!**

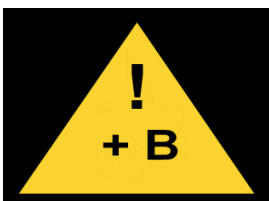

**The connection of the orange cable (+B) is essential for the correct function of the safety features. It prevents a deepening of the jacks by accident on tour.**

## Initial operation

After finishing the wiring press the button **ON/OFF** on the control panel. All LED's flash one after another, at last the LED **GET UP**. It shows the correct wiring. Press again **ON/OFF** to switch off the system and start the next chapter. In case another LED is on please see chapter malfunctions.

## Adjusting of limit switches

The jacks are equipped with adjustable limit switches.

**The point of switching-off must be adjusted correctly at every jack to avoid the motor of the jack is still running when it cannot move anymore. Start now with a special function:**

Switch over to „calibration mode“:

Press button **ON/OFF** to start the system.

Directly after while the LED procedure is running press the 4 arrow buttons at once and hold them until the LED **MANUAL** lights up. Release the buttons. Press again the button **MANUAL** and the arrow buttons are constantly lighted.

In this mode the jacks can be moved separately up and down to adjust the limit switches. Pressing one arrow button the corresponding jack runs **up** to driving position. Pressing **MANUAL** and one arrow button the corresponding jack runs **down**.

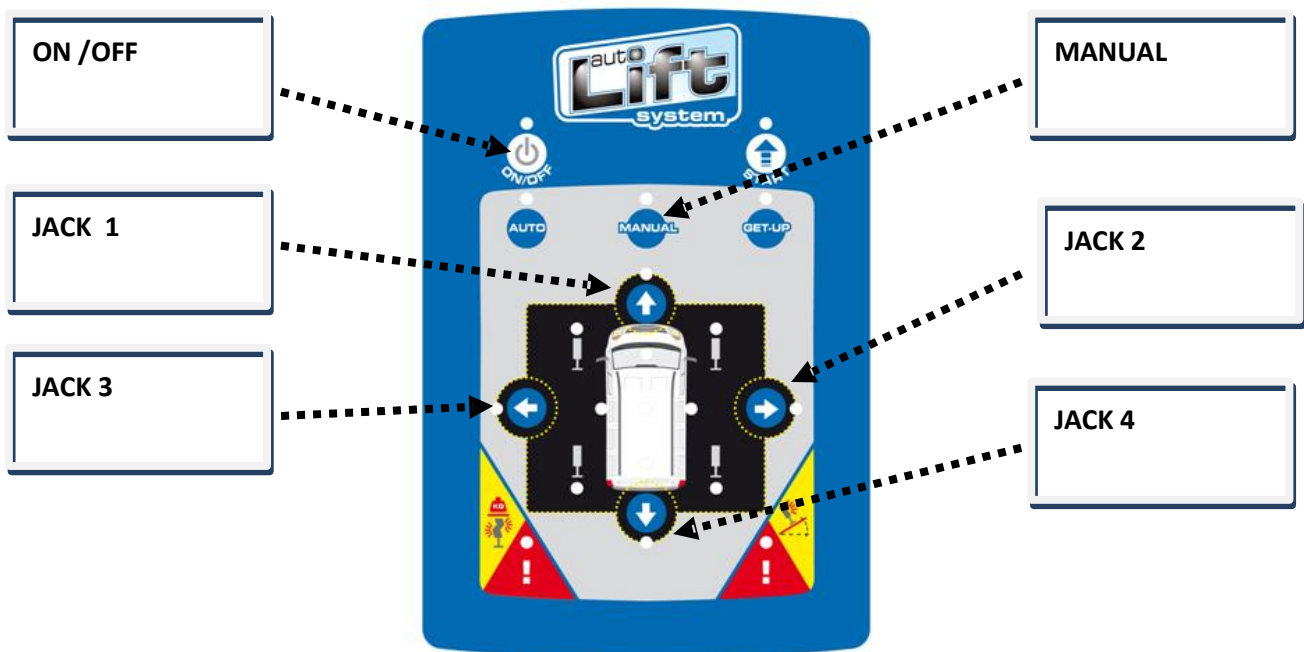

Start now the adjustment of the jacks.

1. Press the arrow button of jack 1 until it reaches the driving position. The system answers with a long beep.
2. Adjust with the screw (see picture below) by turning in a later point or turning out an earlier point of switching off.
3. Move again the jack down and up to the point of switching off.
4. Repeat this procedure until the adjustment is correct. Then fix the lock nut.
5. Repeat 1-4 at all jacks in the same manner.
6. Move all jacks to driving position if not yet done.
7. Finish the calibration mode by pressing **ON/OFF**.
8. Switch ON/OFF again. The system starts now the self control shown by the flashing LED's. At last the LED START lights up. If not the LED **GET UP** lights up. It shows that one or more limit switches are not closed correctly. In this case control and adjust the limit switches again.

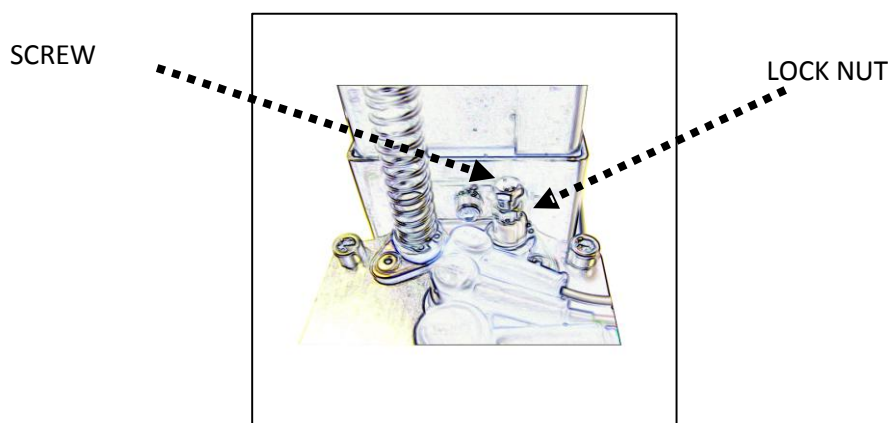

**Important remarks for the adjustment**



The limit switches must not react at the mechanical end point of the jack. There must remain a duty cycle. To control the duty cycle bring the jack to the driving position and press the jack with the hand upwards. The play between electrical and mechanical end point must be about 1 cm.

If the limit switches are not adjusted correctly the most functions are blocked. Pay attention to accurate adjustment.

## Programming the remote control

The remote control is factory-provided pre-programmed and saved in the control unit. Complete this chapter only in case of changing the remote control.

1. Switch off the system. Press and hold at once **START** and **ON/OFF** on the panel. Don't release the buttons.
2. Press **START** on the remote control. 2 beeps confirm the saving. Wait 2 seconds and press **AUTO** on the remote control. Again you get 2 beeps. Wait again 2 seconds and press **GET UP** on the remote control, again you will hear 2 beeps.
3. Release the buttons **START** and **ON/OFF** on the panel.

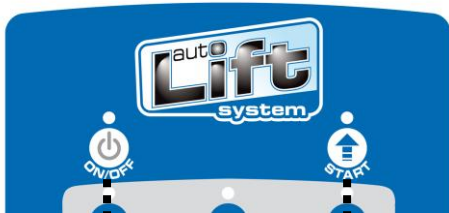

Press and hold at once





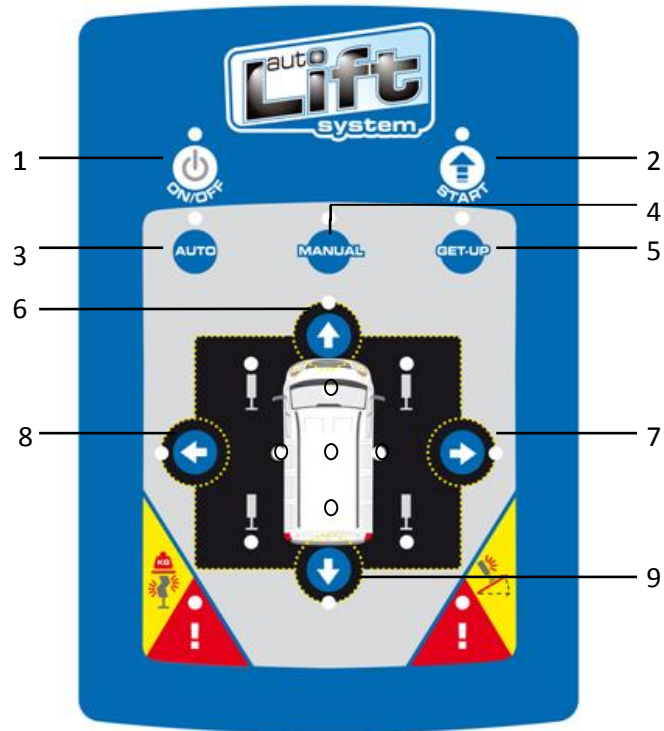

Press one after another  
START – AUTO – GET-UP

## Control panel

### Description of buttons



- |  |   |
|--|---|
| 1.   | ON/OFF : System switch                        |
| 2.   | START : begins the start phase*               |
| 3.   | AUTO: begins the automatic levelling*         |
| 4.   | MANUAL: activates manual levelling*           |
| 5.   | GET-UP : lifts all jacks to driving position* |
| 6.  | : ascend front jacks (manual)                 |
| 7.  | : ascend rear jacks (manual)                  |
| 8.  | : ascend left jacks (manual)                  |
| 9.  | : ascend right jacks (manual)                 |

\*see detailed description of functions

## Control panel

### Description of LED's

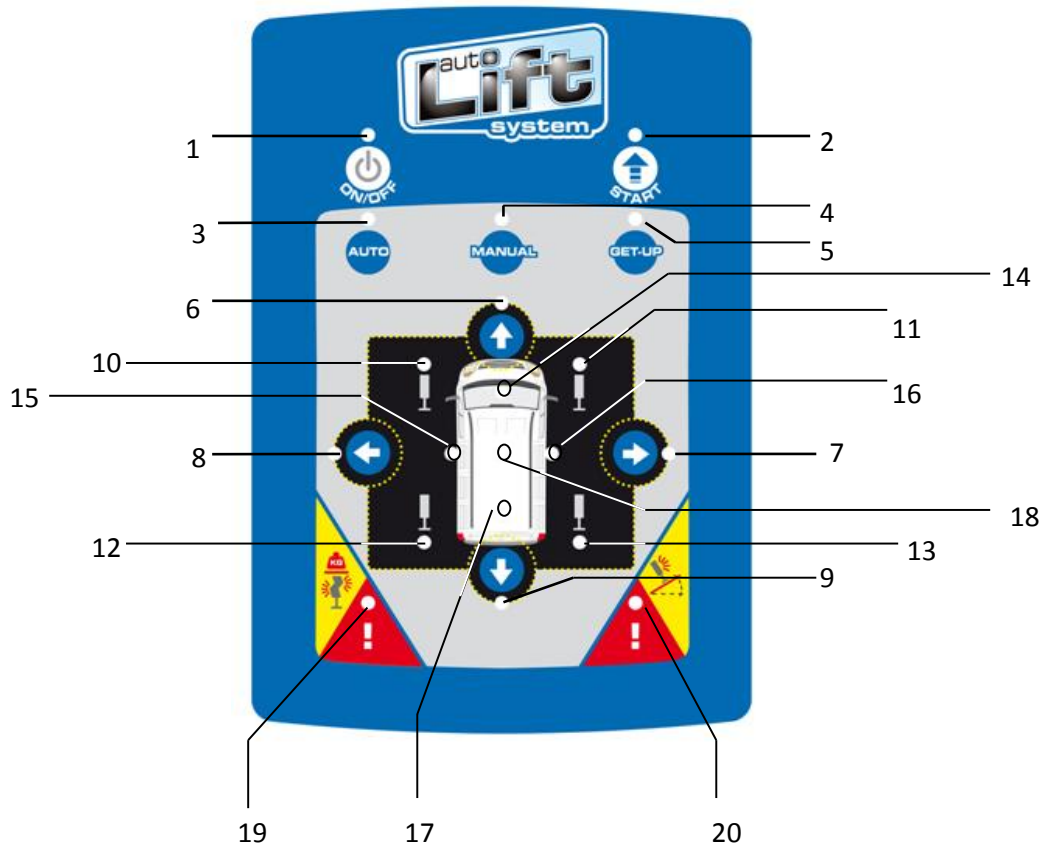

1. Red LED System on
2. Green LED ready for phase START
3. Red LED: ready for automatic levelling
4. Red LED: ready for manually levelling
5. Red LED ready for GET UP
6. yellow LED: button front jacks activated
7. yellow LED: button right jacks activated
8. yellow LED: button left jacks activated
9. yellow LED: button rear jacks activated
- 10.11. 12. 13. Red LED's: overload or malfunction\*
- 14.15. 16. 17. Red LED's: level indicator: shows the side which must be lifted
18. Green LED: levelling correct (like programmed)
19. Red LED: overload \*
20. Red LED: a high inclination \*

## Detailed description of functions

In the following the several functions of the Autolift system are exactly described. Before using the system please read this manual attentively. The below described functions are **only available at ignition off**. Nevertheless it is possible to use the most functions with running motor, except the safety functions (see chapter).



### ON/OFF (taste 1)

Press **ON/OFF** to switch on the system, shortly after the system starts Autotest\*, this is the control sequence with flashing LED's. At the end of the test, if all jacks are in driving position, the LED **START** lights up and shows the system can be operated now. If not all jacks are in driving position the LED **GET UP** is on and shows there is only this function available.

\*if the control sequence does not start look to the panel if there are other LED's lighted and show a malfunction. See chapter.

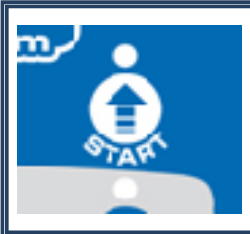

### START (taste 2)

Press **START** to operate the first step of levelling functions. The jacks ascend to vertical position and wait for the next order. This safety function is necessary to control visually the free running of jacks. In this position you have the possibility to put spacers between jack and floor. At the end of phase **START** the LED's **AUTO\*** - **MANUAL** – **GET UP** are lighted and show the availability of these functions.

\*If the LED **AUTO** is not lighted the automatic levelling is not possible, shown by the LED unacceptable incline. Then you can use the manual leveling, but a correct leveling cannot be guaranteed



### **AUTO** (taste 3)

After the phase **START** the automatic levelling can be started with the button **AUTO**. The jacks ascend to the ground and the control unit finishes the levelling. At any time two jacks are moving to share lifting power and to avoid torsions. At the end of levelling the green LED 18 lights up and shows the correct levelling. During the function **AUTO** only the function **GET UP** is available.

If the LED 20 (a high inclination) lights up the correct levelling is not possible because the remaining travel of jacks is not enough. In this case the system tries to reach the best possible position. The jacks at the greatest incline take then precedence over the others. Alternatively the function **MANUAL** can be used in order to reach a better level.



### **MANUAL** (taste 4)

The manual levelling can be started after end of phase **START**. This function is also usable for lifting one side of the vehicle for changing wheels or to fit snow chains and better draining of tanks. Pressing **MANUAL** all jacks ascend at once to the ground. At this point the 4 yellow LED's are lighted and the arrow buttons can be operated. Every arrow button moves a pair of jacks (front, rear, left, right). At any time two jacks are moving to share lifting power and to avoid torsions.

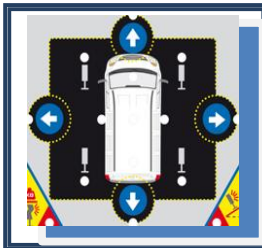

Level the vehicle manually with regards to the level indicator. LED lighted means this side must be lifted. In the best possible case the green LED lights up and shows correct levelling. If the jacks are at end of stroke you will hear an alarm overload shown by LED 19. Press again **MANUAL** if one jack has not yet reached the ground after finishing the manual levelling. This is better for stability and does not change the reached level.



### **GET-UP** (taste 5)

Press **GET UP** to release the jacks from the ground. They stop at the point of pivoting. At this point eventually used spacers must be removed. You will hear intermitted beeps from the system. Pressing again **GET UP** the jacks go to the driving position.

**IMPORTANT:** used spacers etc. must be removed before pivoting the jacks. Deformed mechanics or ruptured weld seams could be the consequence.

The achievement of driving position for all jacks is shown by a long beep and the LED **START** lights up.

## Remote control



The main functions can be operated outside with the remote control. So you have eye contact to the working jacks, you can control the floor conditions and set spacers. Only the functions **START – AUTO – GET-UP** are available, other functions must be operated at the control panel.

## Signalisation of alarms



### Alarm overload (LED 19)

In case of overload of one or more jacks the LED 19 lights up together with one LED 10-11-12-13. It shows which jack is in overload position.

This LED can also be lighted if one of the jacks is at the end of stroke. In this case the jack is blocked and only the function **GET UP** is available.



### Alarm a high inclination (LED 20)

This LED lights up if the incline of the vehicle is more than the jacks can balance. Pressing **AUTO** the systems tries the best possible position, but the correct level cannot be guaranteed. Alternatively the function **MANUAL** can be used in order to reach a better level.

## Special functions

### Blocking all functions when ignition on

If the ignition is on or the motor is running the jacks cannot be served on principle. This safety function is necessary to avoid ascending during the trip. If you turn on the ignition the system will block all functions. If all jacks are in driving position you will not hear a beep. If only one jack is still a little bit ascended you will get an optic and acoustic sign on the panel, which shows to get up the jacks.

### Operation of system with running motor (+B correctly connected)

The safety function above can be switched off f.e. to load the starter battery.



Press at least 5 seconds **START** until the LED START lights up. Now all functions are available. After switching off the system returns to standard mode automatically. You cannot use the remote control for this function.

**! USE THIS FUNCTION CAREFULLY AND WITH HIGHEST ATTENTION**

### AUTO POWER-OFF

After 5 minutes the system switches off automatically if it is not operated. This saves the battery.

## Signalisation of malfunctions

The system passes an Autotest after switching on and controls electronically all functions, all LED's are lighting on after another and a beep sign the system is ok. If something is going wrong the malfunction is shown by different LED's on the panel:

**LED's 10-11-12-13:** The limit jack is defect, not connected or not correctly adjusted. In this case it is possible the function GET UP is not available. Nevertheless you have the possibility to put the jacks in driving position (see chapter emergency operation).

**LED's 14-15-16-17-18 synchronous :** The correct levelling is not or not yet programmed and stored. See chapter "storing the correct levelling".

## Troubleshooting

Some typical malfunctions and possible reasons:

**System cannot be switched on:** Control the fuse in the red power line. Control the connection between panel and control unit. Try it with another network cable.

**LED START does not light up:** one of the limit switches is not correctly adjusted. Control all switches and adjust them like shown on page 11.

**The vehicle is not in balance after using AUTO:** The correct level is stored in the control unit. Nevertheless it is possible the balance is not correct if the control box is fitted incorrectly in a false position. Correct the position of the box and store a new level like shown in the next chapter.

## Storing the correct levelling

The fault tolerance of automatic levelling is about 0.3° in both directions. Use this procedure only if you want a better result of automatic levelling.

1. Use the function MANUAL, controlled with spirit level
2. Switch off the system.
3. Switch on system again and right after that press and hold AUTO - MANUAL - GET-UP at once until 7 beeps from the panel.
4. Release the buttons, the level is stored.

## Emergency operation

In case of damage a tone jack the malfunction is shown on the panel by the related LED and the function GET UP is not available. Please use following instruction to put the jacks in driving position:

1. Switch over to "calibration mode" like described in the chapter adjustment of limit switches on page 10
2. Bring all jacks separately to the driving position.

In case of a mechanical damage at the jacks or total electrical breakdown use the following instructions to put the jacks into driving position:

Use the car-jack from the vehicle equipment and lift the vehicle until the jack is released from the floor. Clap the jack manually into driving position and fix it with cord, wire or the like in this position. Inform your dealer / garage to solve the problem.

**Warranty:**

In case of defects by legal using we guarantee for spare parts free of charge up to 2 years beginning from buying date. The manufacturer is not responsible for freights, times or other additional costs. The manufacturer is not responsible for damages caused by false using and/or fitting. Warranty requests must be made with the dated buying receipt and the completed form annexed.

<b>Technical Data</b>	
<b>Lifting force dynamic</b>	Kg 2500 each jack, electronically controlled
<b>Lifting force static</b>	Kg 5000 each jack
<b>Total course</b>	mm 150
<b>Usable course</b>	mm 120
<b>speed max.</b>	5 mm /sec.
<b>Consumption at 1000kg lifting force</b>	12 A
<b>Maximum levelling Longitudinal axle (X)</b>	≥4° (8 %)
<b>Maximum levelling diagonal axle (Y)</b>	≥6° (12 %)
<b>Time automatic levelling</b>	Max 60 sec.
<b>Measures vertical</b>	Changeable from 300 mm to 420 mm step by 10mm
<b>Consumption switched off</b>	0 A
<b>Weight jack</b>	~ Kg 11
<b>Weight total</b>	~ Kg 50
<b>Conformity</b>	89/336/CE
<b>Range of temperature</b>	-30 ÷ 50 °C
<b>Precision automatic levelling</b>	±0,3°

Subject to change without prior notice

